



Service Bulletin

American Honda Motor Co., Inc.

SAFETY RECALL

2002-2004 GL1800/A

Linked Braking System (LBS) Proportional Control Valve (PCV) Leakage

American Honda is conducting a Safety Recall to inspect the Linked Braking System (LBS) proportional control valve (PCV) on affected 2002-2004 GL1800/A models.

The PCV could develop a leak. Over time, the leak could result in a total loss of brake fluid in the rear brake system. If the motorcycle continues to be used after a leak occurs, the rear brake would eventually become inoperative. In the worst case, a loss of rear brake force may cause a crash without warning.

All affected units will have the PCV inspected and replaced as required.

AFFECTED UNITS

2002 GL1800

1HFSC470*2A111443 thru 1HFSC470*2A113582

2002 GL1800A

1HFSC474*2A102394 thru 1HFSC474*2A102823

2003 GL1800

1HFSC470*3A200001 thru 1HFSC470*3A212217

2003 GL1800A

1HFSC474*3A200001 thru 1HFSC474*3A203256

2004 GL1800

1HFSC470*4A300001 thru 1HFSC470*4A306927

2004 GL1800A

1HFSC474*4A300001 thru 1HFSC474*4A301749

(*) Denotes check digit.

CUSTOMER NOTIFICATION

American Honda is sending a letter to owners of all affected 2002-2004 GL1800/A models, advising them to take their motorcycle to a Honda motorcycle dealer to have the Safety Recall procedure performed.

Your assistance is needed to ensure your GL1800/A customers are informed of this Safety Recall. A copy of the customer letter is reproduced on page 5 of this Service Bulletin.

DEALER INVENTORY

Some units affected by this Safety Recall may be in your inventory. **According to federal law, these units cannot be sold until they are repaired.** Refer to the INSPECTION/REPAIR PROCEDURE section of this Service Bulletin.

INSPECTION/REPAIR VERIFICATION

Before you begin the inspection/repair procedure, check if the inspection/repair has been performed on the unit. See the IDENTIFICATION section of this Service Bulletin for more details.

- If there is a punch mark on the VIN plate, the unit has been inspected/repared and no further action is required.

CUSTOMER INFORMATION: The information in this bulletin is intended for use only by skilled technicians who have the proper tools, equipment, and training to correctly and safely maintain your Honda. These procedures should not be attempted by "do-it yourselfers," and you should not assume this bulletin applies to your Honda, or that your Honda has the condition described. To determine whether this information applies, contact an authorized Honda dealer.

- If there is no punch mark on the VIN plate, the unit has not been inspected/repaired, and you must proceed to the INSPECTION/REPAIR PROCEDURE section of this Service Bulletin.

NOTE: Verification of the repair can also be found in the *Dealer Responsibility Report* and on **IN**. If you have any questions about repair verification, please contact your DSM or TechLine at (800) 421-1900 before proceeding.

INSPECTION/REPAIR PROCEDURE

Before beginning these procedures, place the motorcycle in a secure area of the shop, on a firm, level surface where it will not be disturbed.

1. Pump the rear brake pedal four times.
 - If the brake pedal feels spongy, bleed the brake system per the Service Manual. After verifying proper brake system operation, proceed to step 2 below.
 - If the brake pedal does not feel spongy, proceed to step 2 below.

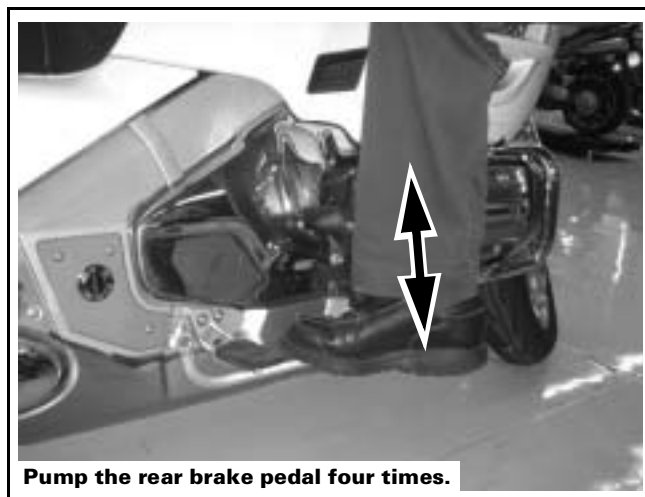

2. Place the motorcycle on its side stand, with the handlebars in the **full left position**. Lock the handlebars.
3. Place a scissor jack directly under the left front brake caliper as shown in the illustration. To avoid damage to the caliper, place a protective piece of rubber (such as a

piece of inner tube) between the caliper and the jack.

Wind up the jack until the front wheel is approximately 15 mm off the ground.



4. Measure the distance from the secondary master cylinder piston mounting bolt to the edge of the secondary master cylinder body (rod length of the secondary master cylinder). **Record this measurement.**
 - If the measured length is **30.3 mm**, replace the PCV per the Service Manual. (This length indicates the unit's secondary master cylinder is fully stroked, which means there is no hydraulic brake pressure acting on the PCV.) After replacing the PCV, proceed to the IDENTIFICATION section of this Service Bulletin.
 - If the measured length is **longer than 30.3 mm**, proceed to step 5 below.

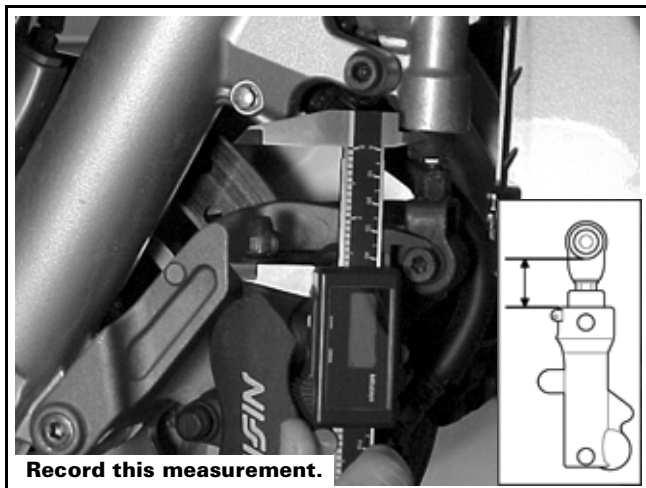

5. Wait 30 minutes. Do not disturb the motorcycle in any way during this time.

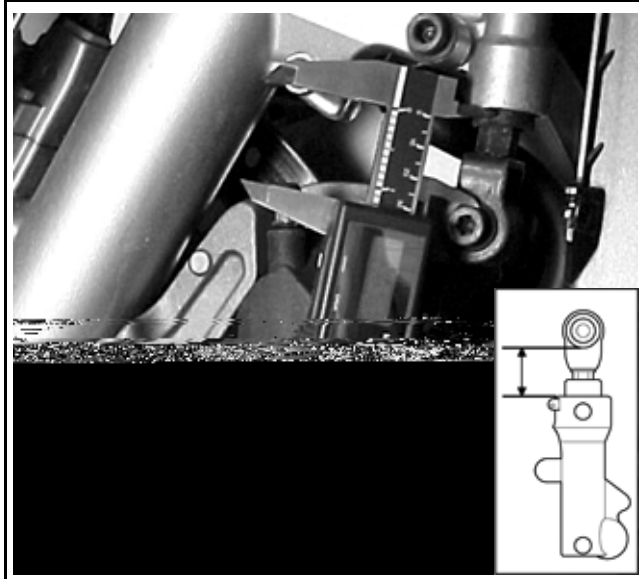

6. Measure the distance again from the secondary master cylinder piston mounting bolt to the edge of the secondary master cylinder body (rod length of the secondary master cylinder).

- If the measurement has **decreased more than 1 mm** from the measurement you recorded, proceed to step 7 below.
- If the measurement is within **1 mm** of the measurement you recorded, the PCV is OK. Proceed to the IDENTIFICATION section of this Service Bulletin.

7. Check the PCV for leakage.

- **If the PCV is leaking**, replace the PCV per the Service Manual. After replacing the PCV, proceed to the IDENTIFICATION section of this Service Bulletin.
- **If the PCV is not leaking**, you must diagnose the brake system problem before proceeding.

After you have diagnosed and repaired the brake system, proceed to the IDENTIFICATION section of this Service Bulletin.

NOTE: Any brake system problem not related to the PCV that is found while performing this Service Bulletin is not covered by this Safety Recall. If the motorcycle's original factory warranty is still in effect or under HPP, file a normal warranty claim.

If the unit is outside its factory warranty period or HPP coverage, contact TechLine for goodwill consideration.

8. Verify proper front and rear brake operation by **pumping the front brake lever and rear brake pedal** before riding the motorcycle.

IDENTIFICATION

Place a punch mark on the VIN plate in the location shown below.

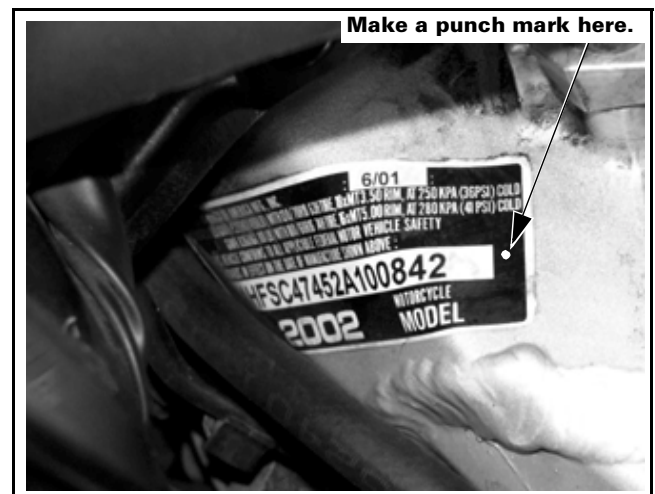

PARTS INFORMATION

Do not order the required parts at this time. Please complete the inspection procedure first, to determine if parts are required.

If the PCV needs to be replaced, call TechLine, on **(800) 421-1900**, to request the required parts.

GL1800:

PCV Set
P/N: 46250-MCA-305
H/C: 8000853

GL1800A:

PCV Set
P/N: 46250-MCA-306
H/C: 8000861

Use only:

Pro Honda DOT 4 Brake Fluid, 12 oz.
P/N: 08203-0004
H/C: 2963734

(or commercially available equivalent)

Note: The cost of brake fluid is built into the flat rate time.

WARRANTY INFORMATION

This Safety Recall will be in effect until all units have been inspected/repaired according to this Service Bulletin, regardless of the date of purchase.

Normal warranty claim submission requirements apply. After completing the Safety Recall, submit one warranty claim per unit with the following information:

WARRANTY CLAIM TEMPLATES:

2002-2004 GL1800 Inspection only

Template: P65A
Flat Rate Time: 0.7 hours

2002-2004 GL1800A Inspection only

Template: P65C
Flat Rate Time: 0.7 hours

2002-2004 GL1800 Inspection and PCV Replacement

Template: P65B
Flat Rate Time: 3.1 hours

2002-2004 GL1800A Inspection and PCV Replacement

Template: P65D
Flat Rate Time: 3.1 hours

TEXT OF CUSTOMER LETTER

February 2005

IMPORTANT SAFETY RECALL NOTICE

Dear Honda Motorcycle Owner:

This notice is sent to you in accordance with the requirements of the National Traffic and Motor Vehicle Safety Act.

What is the reason for this notice?

Honda Motor Co., Ltd. has decided that a defect relating to motor vehicle safety exists in certain 2002-2004 model year GL1800/A motorcycles. The brake proportioning valve could develop a leak. Over time, the leak could result in a total loss of brake fluid in the rear brake system. If the motorcycle continues to be used after a leak occurs, the rear brake would eventually become inoperative. In the worst case, a loss of rear brake force may cause a crash without warning.

What should you do?

Call any authorized Honda motorcycle dealer and make an appointment to have your motorcycle inspected. The dealer will inspect the brake system. If seal leakage is confirmed, the dealer will install a new proportioning valve. The inspection and any necessary repair will be done *free of charge*. Please plan to leave your motorcycle for at least one day to allow the dealer flexibility in scheduling.

Who to contact if you experience problems.

If you are not satisfied with the service you receive from your Honda dealer, you may write to:

American Honda Motor Co., Inc.
Motorcycle Customer Support
Mail Stop 100-4W-5B
1919 Torrance Blvd.
Torrance, CA 90501-2746

If you believe that American Honda or the dealer has failed or is unable to remedy the defect in your motorcycle, without charge, within a reasonable period of time (60 days from the date you first contact the dealer for a repair appointment), you may submit a complaint to:

Administrator
National Highway Traffic Safety Administration
400 Seventh Street, SW
Washington, DC 20590

Or call the toll-free Safety Hotline at (888) 327-4236.

What to do if you feel this notice is in error.

Our records show that you are the current owner of a 2002-2004 GL1800/A involved in this recall. If this is not the case, or the name/address information is not correct, please fill out and return the enclosed, postage-paid *Information Change Card*. We will then update our records.

If you already paid to have your rear brake repaired sometime in the past, you may be eligible for reimbursement. Refer to the attached *Request for Reimbursement* for eligibility requirements and the reimbursement procedure.

If you have questions.

If you have any questions about this notice, or need assistance with locating a Honda dealer, please call Motorcycle Customer Support at (866) 784-1870. You may also visit our Web site at www.hondamotorcycle.com and click on "Locate a Dealer" to locate a Honda dealer who can assist you.

We apologize for any inconvenience this campaign may cause you.

Sincerely,
American Honda Motor Co., Inc.
Honda Motorcycle Division

REQUEST FOR REIMBURSEMENT

**2002-2004 GL1800/A
Linked Braking System (LBS) Proportional Control Valve (PCV) Leakage**

If you meet the following qualifications, American Honda Motor Co., Inc. will reimburse you for the cost of replacing the PCV and related parts. No reimbursement will be made for other costs or repairs.

1. The vehicle must be an affected 2002-2004 GL1800/A.
2. The PCV and related parts must have been replaced before February 3, 2005.
3. You must have replaced the PCV and related parts as a result of a failure of the PCV.
4. You must have a repair bill showing itemized parts and labor costs, identifying the GL1800/A model, year, and VIN; the name, address, and telephone number of the repair shop; and the date of the repair. There must be verification of payment, such as a copy of a cancelled check, cash receipt, or paid invoice.
5. To qualify for reimbursement, it is not necessary that you still own the affected 2002-2004 GL1800/A, but you must have been the owner when the repair was performed. Only the owner at the time of repair may request reimbursement. Do not request reimbursement for the expenses of any other owner.

IF YOU ARE QUALIFIED FOR REIMBURSEMENT:

Fill in the blanks; please print clearly.

Name _____

Street Address _____

City _____ State _____

Telephone _____ ZIP _____

Vehicle Identification Number (VIN) _____

Total Amount Requested _____

Mail this form, together with a copy of your repair bill and verification of payment, to American Honda Customer Support:

American Honda Motor Co., Inc.
Customer Support, M/S 100-4W-5B
1919 Torrance Blvd.
Torrance, CA 90501-2746

Please allow 6-8 weeks for reimbursement processing.

This form is provided for dealer information and customer photocopies if needed.